

REVISIONS			
LTR	DESCRIPTION	DATE (YR-MO-DA)	APPROVED
A	Make change to table II. Drawing updated to reflect current requirements. - ro	00-07-19	R. MONNIN
B	Drawing updated to reflect current requirements. - ro	03-04-25	R. MONNIN

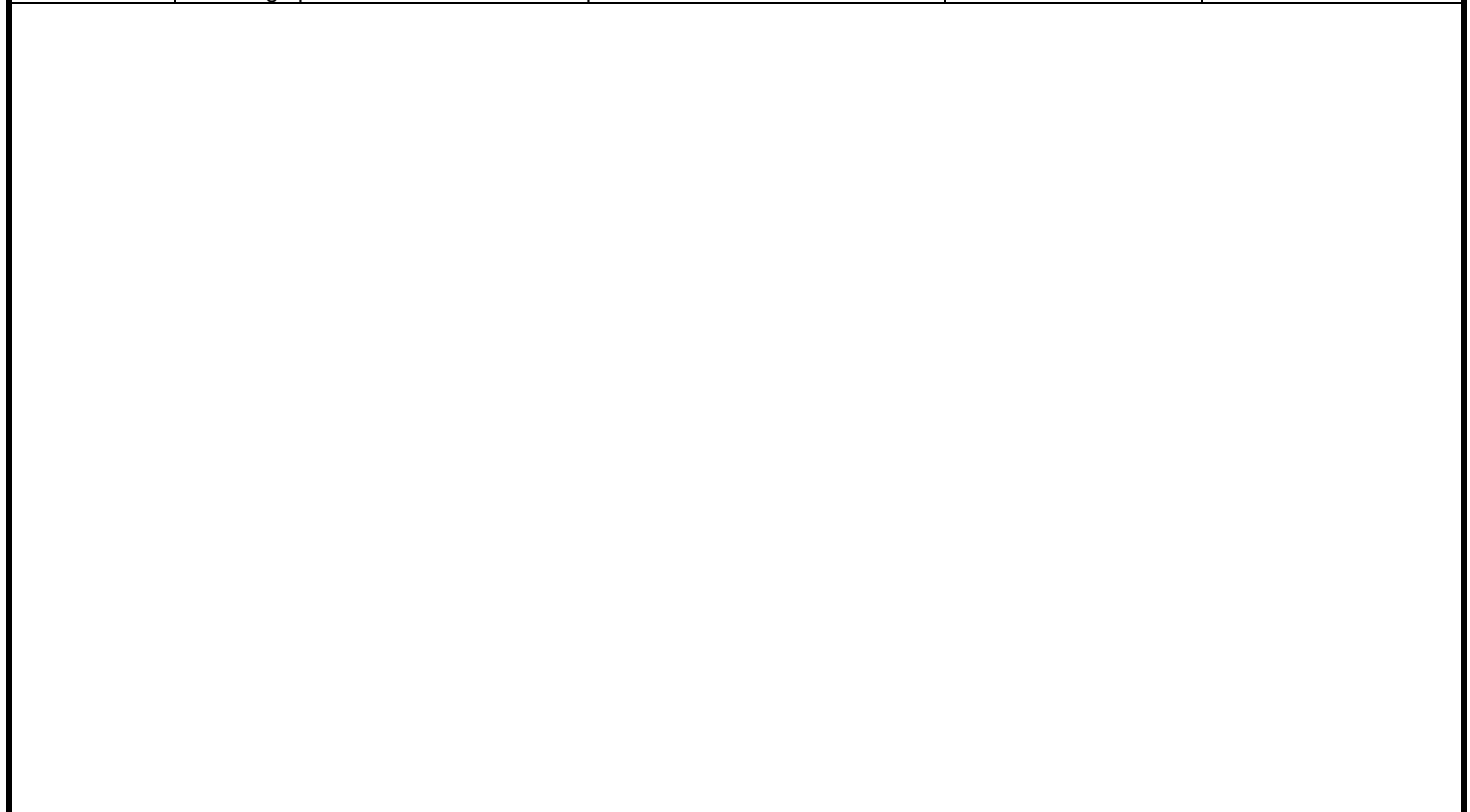

REV																				
SHEET																				
REV																				
SHEET																				
REV STATUS	REV	B	B	B	B	B	B	B	B	B	B	B	B	B						
OF SHEETS	SHEET	1	2	3	4	5	6	7	8	9	10	11								
PMIC N/A	PREPARED BY MARCIA B. KELLEHER				<p align="center">DEFENSE SUPPLY CENTER COLUMBUS COLUMBUS, OHIO 43216 http://www.dsccl.dla.mil</p>															
<p align="center">STANDARD MICROCIRCUIT DRAWING</p> <p align="center">THIS DRAWING IS AVAILABLE FOR USE BY ALL DEPARTMENTS AND AGENCIES OF THE DEPARTMENT OF DEFENSE</p> <p align="center">AMSC N/A</p>	CHECKED BY CHARLES E. BESORE																			
	APPROVED BY MICHAEL A. FRYE				<p align="center">MICROCIRCUIT, LINEAR, LVDT SIGNAL CONDITIONER, MONOLITHIC SILICON</p>															
	DRAWING APPROVAL DATE 92-12-30																			
	REVISION LEVEL B				SIZE A	CAGE CODE 67268	5962-90671													
				SHEET 1 OF 11																

1.3 Absolute maximum ratings. 1/

Total supply voltage, (+V _S to -V _S)	36 V dc
Power dissipation to +65°C	1.2 W 2/
Junction temperature (T _J)	+175°C
Storage temperature range	-65°C to +150°C
Lead temperature (soldering, 60 seconds)	+300°C
Thermal resistance, junction-to-case (θ _{JC})	25°C/W
Thermal resistance, junction-to-ambient (θ _{JA})	85°C/W

1.4 Recommended operating conditions.

Total power supply voltage (V _S)	30 V dc
Ambient operating temperature range (T _A)	-55°C to +125°C

2. APPLICABLE DOCUMENTS

2.1 Government specification, standards, and handbooks. The following specification, standards, and handbooks form a part of this drawing to the extent specified herein. Unless otherwise specified, the issues of these documents are those listed in the issue of the Department of Defense Index of Specifications and Standards (DoDISS) and supplement thereto, cited in the solicitation.

SPECIFICATION

DEPARTMENT OF DEFENSE

MIL-PRF-38535 - Integrated Circuits, Manufacturing, General Specification for.

STANDARDS

DEPARTMENT OF DEFENSE

MIL-STD-883 - Test Method Standard Microcircuits.
 MIL-STD-1835 - Interface Standard Electronic Component Case Outlines.

HANDBOOKS

DEPARTMENT OF DEFENSE

MIL-HDBK-103 - List of Standard Microcircuit Drawings.
 MIL-HDBK-780 - Standard Microcircuit Drawings.

(Unless otherwise indicated, copies of the specification, standards, and handbooks are available from the Standardization Document Order Desk, 700 Robbins Avenue, Building 4D, Philadelphia, PA 19111-5094.)

2.2 Order of precedence. In the event of a conflict between the text of this drawing and the references cited herein, the text of this drawing takes precedence. Nothing in this document, however, supersedes applicable laws and regulations unless a specific exemption has been obtained.

1/ Stresses above the absolute maximum rating may cause permanent damage to the device. Extended operation at the maximum levels may degrade performance and affect reliability.
 2/ Derates above +65°C by 12 mW/°C.

STANDARD MICROCIRCUIT DRAWING DEFENSE SUPPLY CENTER COLUMBUS COLUMBUS, OHIO 43216-5000	SIZE A		5962-90671
		REVISION LEVEL B	SHEET 3

3. REQUIREMENTS

3.1 Item requirements. The individual item requirements for device classes Q and V shall be in accordance with MIL-PRF-38535 and as specified herein or as modified in the device manufacturer's Quality Management (QM) plan. The modification in the QM plan shall not affect the form, fit, or function as described herein. The individual item requirements for device class M shall be in accordance with MIL-PRF-38535, appendix A for non-JAN class level B devices and as specified herein.

3.2 Design, construction, and physical dimensions. The design, construction, and physical dimensions shall be as specified in MIL-PRF-38535 and herein for device classes Q and V or MIL-PRF-38535, appendix A and herein for device class M.

3.2.1 Case outline. The case outline shall be in accordance with 1.2.4 herein.

3.2.2 Terminal connections. The terminal connections shall be as specified on figure 1.

3.2.3 Block diagram. The block diagram shall be as specified on figure 2.

3.3 Electrical performance characteristics and post irradiation parameter limits. Unless otherwise specified herein, the electrical performance characteristics and post irradiation parameter limits are as specified in table I and shall apply over the full ambient operating temperature range.

3.4 Electrical test requirements. The electrical test requirements shall be the subgroups specified in table II. The electrical tests for each subgroup are defined in table I.

3.5 Marking. The part shall be marked with the PIN listed in 1.2 herein. In addition, the manufacturer's PIN may also be marked as listed in MIL-HDBK-103. For packages where marking of the entire SMD PIN number is not feasible due to space limitations, the manufacturer has the option of not marking the "5962-" on the device. For RHA product using this option, the RHA designator shall still be marked. Marking for device classes Q and V shall be in accordance with MIL-PRF-38535. Marking for device class M shall be in accordance with MIL-PRF-38535, appendix A.

3.5.1 Certification/compliance mark. The certification mark for device classes Q and V shall be a "QML" or "Q" as required in MIL-PRF-38535. The compliance mark for device class M shall be a "C" as required in MIL-PRF-38535, appendix A.

3.6 Certificate of compliance. For device classes Q and V, a certificate of compliance shall be required from a QML-38535 listed manufacturer in order to supply to the requirements of this drawing (see 6.6.1 herein). For device class M, a certificate of compliance shall be required from a manufacturer in order to be listed as an approved source of supply in MIL-HDBK-103 (see 6.6.2 herein). The certificate of compliance submitted to DSCC-VA prior to listing as an approved source of supply for this drawing shall affirm that the manufacturer's product meets, for device classes Q and V, the requirements of MIL-PRF-38535 and herein or for device class M, the requirements of MIL-PRF-38535, appendix A and herein.

3.7 Certificate of conformance. A certificate of conformance as required for device classes Q and V in MIL-PRF-38535 or for device class M in MIL-PRF-38535, appendix A shall be provided with each lot of microcircuits delivered to this drawing.

3.8 Notification of change for device class M. For device class M, notification to DSCC-VA of change of product (see 6.2 herein) involving devices acquired to this drawing is required for any change as defined in MIL-PRF-38535, appendix A.

3.9 Verification and review for device class M. For device class M, DSCC, DSCC's agent, and the acquiring activity retain the option to review the manufacturer's facility and applicable required documentation. Offshore documentation shall be made available onshore at the option of the reviewer.

3.10 Microcircuit group assignment for device class M. Device class M devices covered by this drawing shall be in microcircuit group number 80 (see MIL-PRF-38535, appendix A).

STANDARD MICROCIRCUIT DRAWING DEFENSE SUPPLY CENTER COLUMBUS COLUMBUS, OHIO 43216-5000	SIZE A		5962-90671
		REVISION LEVEL B	SHEET 4

TABLE I. Electrical performance characteristics.

Test	Symbol	Conditions <u>1/</u> -55°C ≤ T _A ≤ +125°C unless otherwise specified	Group A subgroups	Device type	Limits <u>2/</u>		Unit
					Min	Max	
Signal output voltage range	V _{ORS}		1,2,3	01	±11		V
Signal output current	I _{OS}		1,2,3	01	±5		mA
Signal output <u>3/</u> nonlinearity	N _{LOS}		1,2,3	01		±500	ppm of FS
Signal output gain <u>4/</u> error	ΔA _{EOS} / ΔT	T _A = +25°C	1	01		±1	% of FS
Signal output gain drift	ΔA _{DOS} / ΔT	T _A = +125°C and -55°C	2,3	01		±50	ppm/°C of FS
Signal output offset <u>5/</u>	ΔO _{OS} / ΔT	T _A = +25°C	1	01		±1	% of FS
Signal output offset drift	ΔO _{DS} / ΔT	T _A = +125°C and -55°C	2,3	01		±50	ppm/°C of FS
Signal output PSRR gain	A _{PSSRS}	V _S = ±12 V dc to ±18 V dc	1,2,3	01		±400	ppm/V
Signal output PSRR offset	O _{PSSRS}	V _S = ±12 V dc to ±18 V dc	1,2,3	01		±200	ppm/V
Signal output CMRR gain	A _{CMRRS}	V _S = ±3 V dc	1,2,3	01		±200	ppm/V
Signal output CMRR offset	O _{CMRRS}	V _S = ±3 V dc	1,2,3	01		±200	ppm/V
Excitation output voltage	V _{EXO}	R1 = open, measured between LEV 1 and LEV 2 pins, T _A = +25°C	1	01	1.2		V rms
		R1 = 487 kΩ, measured between LEV 1 and LEV 2 pins, T _A = +25°C				20	
Power supply current	I _T	No load at signal and excitation outputs	1	01		15	mA
			2,3			18	

See footnotes at end of table.

**STANDARD
MICROCIRCUIT DRAWING**
DEFENSE SUPPLY CENTER COLUMBUS
COLUMBUS, OHIO 43216-5000

SIZE
A

REVISION LEVEL
B

5962-90671

SHEET
5

TABLE I. Electrical performance characteristics – Continued.

- 1/ $V_S = \pm 15$ V dc, $C_1 = 0.015$ μ F, $R_2 = 80$ k Ω , $R_L = 2$ k Ω , unless otherwise specified.
- 2/ The limiting terms “min” (minimum) and “max” (maximum) shall be considered to apply to magnitudes only. Negative current shall be defined as conventional current flow out of a device terminal.
- 3/ Nonlinearity of the device only in units of ppm of full scale. Nonlinearity is defined as the maximum measured deviation of the output voltage from a straight line. The straight line is determined by connecting the maximum produced full-scale negative voltage with the maximum produced full-scale positive voltage.
- 4/ From -55°C to $+125^\circ\text{C}$, the overall error alone is determined by combing gain error, gain drift, and offset drift. For example, the worst-case overall error from -55°C to $+125^\circ\text{C}$ is calculated as follows: Overall error = gain error at $+25^\circ\text{C}$ (± 1 percent full scale) + gain drift from $+25^\circ\text{C}$ to $+125^\circ\text{C}$ (50 ppm/ $^\circ\text{C}$ FS x $+100^\circ\text{C}$) + offset drift from $+25^\circ\text{C}$ to $+125^\circ\text{C}$ (50 ppm/ $^\circ\text{C}$ of FS x 110°C) = ± 2 percent of full scale. Note that 1000 ppm of full scale equals 0.1 percent of full scale. Full scale is defined as the difference between the maximum positive and the maximum negative output.
- 5/ This offset refers to the $(V_A - V_B) / (V_A + V_B)$ input spanning a full-scale range of ± 1 . For $(V_A - V_B) / (V_A + V_B)$ to equal $+1$, V_B must equal zero volts; and correspondingly for $(V_A - V_B) / (V_A + V_B)$ to equal -1 , V_A must equal zero volts. Note that offset errors do not allow accurate use of zero magnitude inputs; practical inputs are limited to 100 mV rms. The ± 1 span is convenient reference point to define offset referred to input. For example, with this input span a value of $R_2 = 20$ k Ω would give V_{OUT} span a value of ± 10 volts. Caution, most LVDTs will typically exercise less of the $(V_A - V_B) / (V_A + V_B)$ input scan and thus require a larger value of R_2 to produce the $+10$ V output span. In this case, the offset is corresponding magnified when referred to the output voltage. For example, a Schaevitz E100 LVDT requires 80.2 k Ω for R_2 to produce a ± 10.69 volt output and $(V_A - V_B) / (V_A + V_B)$ equals 0.27 . The maximum offset value referred to the ± 10.69 volt output may be determined by multiplying the maximum value shown in the data sheet (± 1 percent of FS by $1/0.27$) which equals ± 3.7 percent values maximum. Similarly, to determine the maximum values of offset drift, offset CMRR and offset PSRR when referred to the ± 10.69 V output, these data sheet values should also be multiplied by $(1/0.27)$. The maximum values of offset drift, PSRR offset, and CMRR offset would be: ± 185 ppm/ $^\circ\text{C}$; ± 741 ppm/V and ± 741 ppm/V, respectively, when referred to the ± 10.69 volt output.

STANDARD MICROCIRCUIT DRAWING DEFENSE SUPPLY CENTER COLUMBUS COLUMBUS, OHIO 43216-5000	SIZE A		5962-90671
		REVISION LEVEL B	SHEET 6

Device type	01
Case outline	R
Terminal number	Terminal symbol
1	-V _S
2	EXC 1
3	EXC 2
4	LEV 1
5	LEV 2
6	FREQ 1
7	FREQ 2
8	B1 FILT
9	B2 FILT
10	V _B
11	V _A
12	A2 FILT
13	A1 FILT
14	OUT FILT
15	FEEDBACK
16	SIG OUT
17	SIG REF
18	OFFSET 2
19	OFFSET 1
20	+V _S

FIGURE 1. Terminal connections.

STANDARD MICROCIRCUIT DRAWING DEFENSE SUPPLY CENTER COLUMBUS COLUMBUS, OHIO 43216-5000	SIZE A		5962-90671
		REVISION LEVEL B	SHEET 7

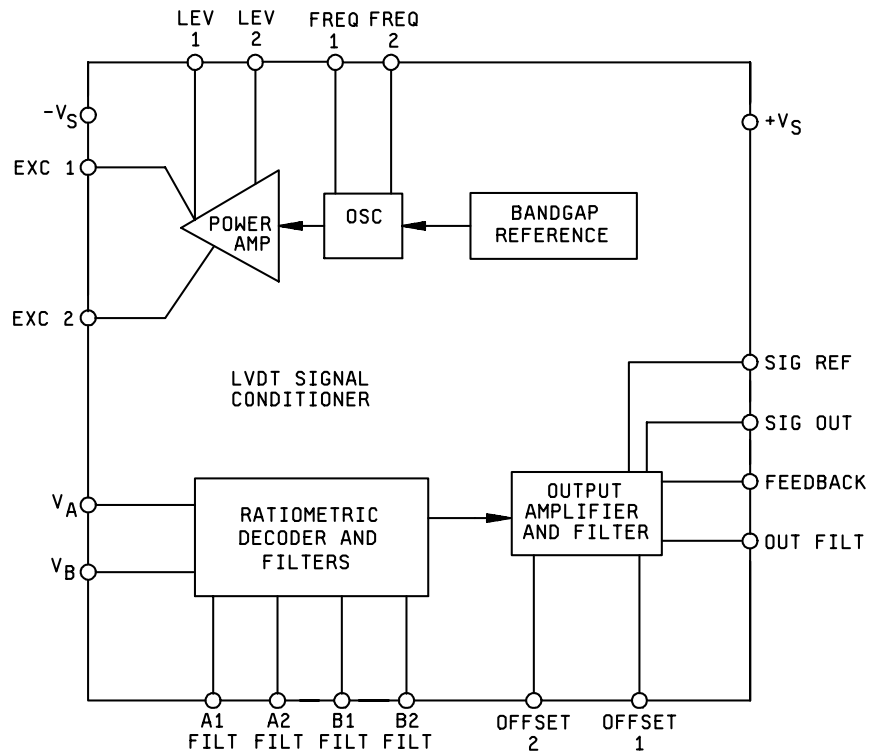

FIGURE 2. Block diagram.

**STANDARD
MICROCIRCUIT DRAWING**
DEFENSE SUPPLY CENTER COLUMBUS
COLUMBUS, OHIO 43216-5000

SIZE
A

5962-90671

REVISION LEVEL
B

SHEET
8

4. QUALITY ASSURANCE PROVISIONS

4.1 Sampling and inspection. For device classes Q and V, sampling and inspection procedures shall be in accordance with MIL-PRF-38535 or as modified in the device manufacturer's Quality Management (QM) plan. The modification in the QM plan shall not affect the form, fit, or function as described herein. For device class M, sampling and inspection procedures shall be in accordance with MIL-PRF-38535, appendix A.

4.2 Screening. For device classes Q and V, screening shall be in accordance with MIL-PRF-38535, and shall be conducted on all devices prior to qualification and technology conformance inspection. For device class M, screening shall be in accordance with method 5004 of MIL-STD-883, and shall be conducted on all devices prior to quality conformance inspection.

4.2.1 Additional criteria for device class M.

a. Burn-in test, method 1015 of MIL-STD-883.

(1) Test condition A, B, C, or D. The test circuit shall be maintained by the manufacturer under document revision level control and shall be made available to the preparing or acquiring activity upon request. The test circuit shall specify the inputs, outputs, biases, and power dissipation, as applicable, in accordance with the intent specified in test method 1015.

(2) $T_A = +125^{\circ}\text{C}$, minimum.

b. Interim and final electrical test parameters shall be as specified in table II herein.

4.2.2 Additional criteria for device classes Q and V.

a. The burn-in test duration, test condition and test temperature, or approved alternatives shall be as specified in the device manufacturer's QM plan in accordance with MIL-PRF-38535. The burn-in test circuit shall be maintained under document revision level control of the device manufacturer's Technology Review Board (TRB) in accordance with MIL-PRF-38535 and shall be made available to the acquiring or preparing activity upon request. The test circuit shall specify the inputs, outputs, biases, and power dissipation, as applicable, in accordance with the intent specified in test method 1015 of MIL-STD-883.

b. Interim and final electrical test parameters shall be as specified in table II herein.

c. Additional screening for device class V beyond the requirements of device class Q shall be as specified in MIL-PRF-38535, appendix B.

4.3 Qualification inspection for device classes Q and V. Qualification inspection for device classes Q and V shall be in accordance with MIL-PRF-38535. Inspections to be performed shall be those specified in MIL-PRF-38535 and herein for groups A, B, C, D, and E inspections (see 4.4.1 through 4.4.4).

4.4 Conformance inspection. Technology conformance inspection for classes Q and V shall be in accordance with MIL-PRF-38535 including groups A, B, C, D, and E inspections and as specified herein. Quality conformance inspection for device class M shall be in accordance with MIL-PRF-38535, appendix A and as specified herein. Inspections to be performed for device class M shall be those specified in method 5005 of MIL-STD-883 and herein for groups A, B, C, D, and E inspections (see 4.4.1 through 4.4.4).

4.4.1 Group A inspection.

a. Tests shall be as specified in table II herein.

b. Subgroups 4, 5, 6, 7, 8, 9, 10, and 11 in table I, method 5005 of MIL-STD-883 shall be omitted.

STANDARD MICROCIRCUIT DRAWING DEFENSE SUPPLY CENTER COLUMBUS COLUMBUS, OHIO 43216-5000	SIZE A		5962-90671
		REVISION LEVEL B	SHEET 9

TABLE II. Electrical test requirements.

Test requirements	Subgroups (in accordance with MIL-STD-883, method 5005, table I)	Subgroups (in accordance with MIL-PRF-38535, table III)	
	Device class M	Device class Q	Device class V
Interim electrical parameters (see 4.2)	1	1	1
Final electrical parameters (see 4.2)	1,2,3 <u>1/</u>	1,2,3 <u>1/</u>	1,2,3 <u>1/</u>
Group A test requirements (see 4.4)	1,2,3	1,2,3	1,2,3
Group C end-point electrical parameters (see 4.4)	1	1	1
Group D end-point electrical parameters (see 4.4)	1	1	1
Group E end-point electrical parameters (see 4.4)	---	---	---

1/ PDA applies to subgroup 1.

4.4.2 Group C inspection. The group C inspection end-point electrical parameters shall be as specified in table II herein.

4.4.2.1 Additional criteria for device class M. Steady-state life test conditions, method 1005 of MIL-STD-883:

- a. Test condition A, B, C, or D. The test circuit shall be maintained by the manufacturer under document revision level control and shall be made available to the preparing or acquiring activity upon request. The test circuit shall specify the inputs, outputs, biases, and power dissipation, as applicable, in accordance with the intent specified in test method 1005 of MIL-STD-883.
- b. $T_A = +125^\circ\text{C}$, minimum.
- c. Test duration: 1,000 hours, except as permitted by method 1005 of MIL-STD-883.

4.4.2.2 Additional criteria for device classes Q and V. The steady-state life test duration, test condition and test temperature, or approved alternatives shall be as specified in the device manufacturer's QM plan in accordance with MIL-PRF-38535. The test circuit shall be maintained under document revision level control by the device manufacturer's TRB in accordance with MIL-PRF-38535 and shall be made available to the acquiring or preparing activity upon request. The test circuit shall specify the inputs, outputs, biases, and power dissipation, as applicable, in accordance with the intent specified in test method 1005 of MIL-STD-883.

4.4.3 Group D inspection. The group D inspection end-point electrical parameters shall be as specified in table II herein.

STANDARD MICROCIRCUIT DRAWING DEFENSE SUPPLY CENTER COLUMBUS COLUMBUS, OHIO 43216-5000	SIZE A		5962-90671
		REVISION LEVEL B	SHEET 10

4.4.4 Group E inspection. Group E inspection is required only for parts intended to be marked as radiation hardness assured (see 3.5 herein).

- a. End-point electrical parameters shall be as specified in table II herein.
- b. For device classes Q and V, the devices or test vehicle shall be subjected to radiation hardness assured tests as specified in MIL-PRF-38535 for the RHA level being tested. For device class M, the devices shall be subjected to radiation hardness assured tests as specified in MIL-PRF-38535, appendix A for the RHA level being tested. All device classes must meet the post irradiation end-point electrical parameter limits as defined in table I at $T_A = +25^{\circ}\text{C} \pm 5^{\circ}\text{C}$, after exposure, to the subgroups specified in table II herein.
- c. When specified in the purchase order or contract, a copy of the RHA delta limits shall be supplied.

5. PACKAGING

5.1 Packaging requirements. The requirements for packaging shall be in accordance with MIL-PRF-38535 for device classes Q and V or MIL-PRF-38535, appendix A for device class M.

6. NOTES

6.1 Intended use. Microcircuits conforming to this drawing are intended for use for Government microcircuit applications (original equipment), design applications, and logistics purposes.

6.1.1 Replaceability. Microcircuits covered by this drawing will replace the same generic device covered by a contractor prepared specification or drawing.

6.1.2 Substitutability. Device class Q devices will replace device class M devices.

6.2 Configuration control of SMD's. All proposed changes to existing SMD's will be coordinated with the users of record for the individual documents. This coordination will be accomplished using DD Form 1692, Engineering Change Proposal.

6.3 Record of users. Military and industrial users should inform Defense Supply Center Columbus when a system application requires configuration control and which SMD's are applicable to that system. DSCC will maintain a record of users and this list will be used for coordination and distribution of changes to the drawings. Users of drawings covering microelectronic devices (FSC 5962) should contact DSCC-VA, telephone (614) 692-0544.

6.4 Comments. Comments on this drawing should be directed to DSCC-VA, Columbus, Ohio 43216-5000, or telephone (614) 692-0547.

6.5 Abbreviations, symbols, and definitions. The abbreviations, symbols, and definitions used herein are defined in MIL-PRF-38535 and MIL-HDBK-1331.

6.6 Sources of supply.

6.6.1 Sources of supply for device classes Q and V. Sources of supply for device classes Q and V are listed in QML-38535. The vendors listed in QML-38535 have submitted a certificate of compliance (see 3.6 herein) to DSCC-VA and have agreed to this drawing.

6.6.2 Approved sources of supply for device class M. Approved sources of supply for class M are listed in MIL-HDBK-103. The vendors listed in MIL-HDBK-103 have agreed to this drawing and a certificate of compliance (see 3.6 herein) has been submitted to and accepted by DSCC-VA.

**STANDARD
MICROCIRCUIT DRAWING**
DEFENSE SUPPLY CENTER COLUMBUS
COLUMBUS, OHIO 43216-5000

SIZE
A

REVISION LEVEL
B

5962-90671

SHEET
11

STANDARD MICROCIRCUIT DRAWING BULLETIN

DATE: 03-04-25

Approved sources of supply for SMD 5962-90671 are listed below for immediate acquisition information only and shall be added to MIL-HDBK-103 and QML-38535 during the next revision. MIL-HDBK-103 and QML-38535 will be revised to include the addition or deletion of sources. The vendors listed below have agreed to this drawing and a certificate of compliance has been submitted to and accepted by DSCC-VA. This bulletin is superseded by the next dated revision of MIL-HDBK-103 and QML-38535.

Standard microcircuit drawing PIN 1/	Vendor CAGE number	Vendor similar PIN 2/
5962-9067101MRA	24355	AD598SD/883B

- 1/ The lead finish shown for each PIN representing a hermetic package is the most readily available from the manufacturer listed for that part. If the desired lead finish is not listed contact the vendor to determine its availability.
- 2/ Caution. Do not use this number for item acquisition. Items acquired to this number may not satisfy the performance requirements of this drawing.

Vendor CAGE number

24355

Vendor name and address

Analog Devices
 Route 1 Industrial Park
 P.O. Box 9106
 Norwood, MA 02062
 Point of contact: 804 Woburn Street
 Wilmington, MA 01887-3462

The information contained herein is disseminated for convenience only and the Government assumes no liability whatsoever for any inaccuracies in the information bulletin.